

INSTRUCTION AND OPERATING MANUAL  
FOR

MODEL 500A  
ELECTRONIC  
FREQUENCY METER  
Serial 2315 and Above

APPLIED PHYSICS STAFF

CALIBRATION AND CERTIFICATION GROUP

MASTER COPY - DO NOT REMOVE FROM  
LABORATORY

HEWLETT-PACKARD COMPANY  
395 PAGE MILL ROAD, PALO ALTO, CALIFORNIA, U.S.A.

## General Description

The Model 500A Frequency Meter directly measures the frequency of an alternating current voltage from 5 to 50,000 cycles/sec. It will operate with the input voltage as low as .5 volts. Variation of the input voltage from .5 to 200 volts or variation of line voltage from 105 to 125 volts has very little effect on the accuracy of the instrument.

This instrument is useful for measuring the beat frequency between two radio frequency signals, crystal frequency deviation, audio frequencies, and for measuring the speed of rotating machinery when used in conjunction with a photo tube and a light source.

### CAUTION

THE MAXIMUM VOLTAGE APPLIED TO THE INPUT TERMINALS OF THIS INSTRUMENT MUST NOT EXCEED 600 VOLTS, THE SUM OF THE DC VOLTAGE AND THE AC PEAK VOLTAGE. HIGHER VOLTAGES WILL BREAK DOWN THE CAPACITOR IN THE INPUT CIRCUIT OF THIS INSTRUMENT.

### Parts Substitutions

Difficulties in procuring some of the parts used in this instrument may cause the electrical or physical values to deviate from those shown in this instruction manual. These substitutions have been made so as not to impair the performance of this instrument. Whenever replacement of any of these parts is necessary, either the substitute value or the original value may be used.

500A 4/24/55 Serial 1/05 & Above

INSTRUCTIONS  
MODEL 500A  
ELECTRONIC FREQUENCY METER

Specifications

Frequency Rating --

Range- 10 to 50,000 cycles/sec. in ten ranges.

Full Scale Indication - 50, 100, 200, and 500 cycles/sec.  
1, 2, 5, 10, 20, and 50 KC/sec.

Input Voltage --

Minimum Input Voltage- .5 volts Variation of the input voltage from  
.5 to 200 volts will affect the meter indication not more than  $\pm 1\%$ .

Input Impedance --

Approximately 300,000 ohms shunted by 37  $\mu$ f.

Accuracy --

$\pm 2\%$  of full scale.

Voltage Stability --

Power line voltage variations from 105 to 125 volts will affect the  
meter indication less than  $\pm 1\%$ .

Recorder Output Characteristics --

Current - 1 ma.

Resistance - 1400 ohms  $\pm 100$  ohms

Power Supply Rating --

Voltage - 105 to 125 volts/210 to 250 volts

Frequency - 50/60 cycles/sec.

Wattage - 65 watts

Overall Dimensions --

Cabinet Model - 19" wide x 8-1/2" high x 11-1/2" deep

Rack Model - 19" wide x 8-3/4" high x 11-1/2" deep

Panel Size - 19" x 8-3/4"

Depth Behind Panel - 10-1/2"

Weight --

Cabinet Model - 20 lbs.  
Rack Model - 20 lbs.

Operating Instructions

Inspection --

This instrument has been thoroughly tested and inspected before being shipped and is ready for use when received.

After the instrument is unpacked, the instrument should be carefully inspected for damage received in transit. If any shipping damage is found, follow the procedure outlined in the "Claim for Damage in Shipment" page at the back of this instruction book.

Controls and Terminals --

INPUT - These binding posts are connected to the input circuit of the frequency meter. The binding post marked G is connected to the chassis.

CAUTION

THE MAXIMUM VOLTAGE APPLIED TO THE INPUT TERMINALS OF THIS INSTRUMENT MUST NOT EXCEED 600 VOLTS, THE SUM OF THE DC VOLTAGE AND THE AC PEAK VOLTAGE. HIGHER VOLTAGES WILL BREAK DOWN THE CAPACITOR IN THE INPUT CIRCUIT OF THIS INSTRUMENT.

TEST - This switch is provided for testing the input voltage level to determine if it is adequate to operate the instrument.

PHOTOTUBE - This jack is provided for connecting a phototube to the instrument to convert the instrument to an electronic tachometer. When the plug is inserted in this jack, the input circuit is changed to match the characteristics of a type IP41 phototube.

USE-LINE FREQ. - CALIBRATE - This switch is used to connect the indicating meter and input circuit to perform several functions. The switch position and corresponding functions are listed below.

Switch Position

Function

USE

The meter is connected to indicate frequency and the INPUT terminals are connected to the input of the amplifier.

LINE FREQ.

The meter is connected to indicate frequency. The 6.3 V.

500A 4/24/53 Serial 1765 & Above

secondary of the power transformer is connected across the input of the amplifier in order to measure the power line frequency as a check on the instrument calibration.

### CALIBRATE

The meter is connected as a DC milliammeter to measure the current drawn by the switching tubes (V4, V5). The current is adjusted so that the meter pointer coincides with the calibration mark on the meter scale. The amplifier input is short circuited when the switch is in this position.

RANGE - This switch is used to insert the correct coupling capacitors and meter shunt resistors in the circuit for any desired range of frequency measurement.

CALIBRATE - This control is used to adjust the current drawn by the switching tubes.

RECORDER - The RECORDER jack is provided for connecting a recorder to the instrument. This instrument is designed to drive an Easterline - Angus Automatic Recorder. However, other recorders may be substituted if their resistance is 1400 ohms  $\pm$ 100 ohms and a full scale indication can be obtained with a current of one milliamperere.

ON - OFF - This toggle switch controls all the power supplied to the instrument from the power line.

FUSE - The fuseholder, located on the back of the instrument, contains a 1 ampere cartridge fuse. To replace the fuse, unscrew the fuseholder cap and remove the blown fuse, insert a new fuse of the same type and replace the fuseholder cap. For 230 volt operation this fuse should have a 1/2 ampere rating. Replacement fuses must be of the "Slo-Blo" type as specified in the Table of Replaceable Parts in this instruction manual.

Power Cable - This is a special three conductor power cable with a standard two prong male plug molded on one end. The third conductor (green) protrudes from the power cable near the plug and may be used to connect the instrument chassis to an external ground.

## Operation --

The procedure for measuring frequency is as follows:

1. Turn the power switch to ON and allow the instrument to warm up for two or three minutes. If maximum accuracy is desired, measurements should not be made until the instrument is completely warmed up.

2. Set the USE-LINE FREQ. -CALIBRATE switch to the CALIBRATE position. Adjust the CALIBRATE control so that the meter pointer coincides with the meter scale division labeled "C" - located at approximately 85 on the 0-100 meter scale. This step in the procedure calibrates the instrument. The calibration should be rechecked occasionally while making measurements.

3. Set the RANGE switch to the 100 $\mu$  range. Change the USE-LINE FREQ. -CALIBRATE switch to the LINE FREQ. position. The frequency of the power line voltage is indicated by the meter. This measurement serves as a check on the calibration of the instrument.

### CAUTION

No external voltage should be applied to the input terminals when the power line frequency is being measured. Application of external voltage may cause inaccurate line frequency measurements.

4. Change the USE-LINE FREQ. -CALIBRATE switch to the USE position and apply the voltage to be measured to the INPUT terminals. Set the RANGE switch to cover the frequency being measured. If the approximate frequency is unknown, turn the RANGE switch to the highest frequency range. Change the switch to successively lower ranges until a range is found that produces a readable meter indication.

5. While the meter is indicating the frequency being measured, depress and hold in the TEST button. If the meter indication is unchanged by this test, then there is sufficient input voltage for the instrument to produce an accurate frequency measurement. Insufficient input voltage, as shown by a lowered meter indication when the TEST button is pressed, will cause inaccurate frequency measurements.

### Attaching a Recorder to the Model 500A -

When a recorder is used with the Model 500A, it is necessary that the compensating resistor in the instrument be adjusted so that the resistance of the recorder matches the instrument.

This adjustment is made as follows:

1. Warm up the instrument and measure either the power line frequency or the frequency of an audio oscillator. Note the frequency indicated by the meter.

500A 4/24/53 Serial 1765 to

2. Plug the lead from the recorder into the RECORDER jack. If the meter (M1) indication is not the same as noted in step 1, adjust R56 (See Fig. 4) so as to produce the same indication as in step 1. When the recorder is disconnected from the RECORDER jack, resistor R56 is removed from the circuit and R53 substituted so that the accuracy of the Model 500A is not impaired.

Using the Model 500A as a Tachometer -

The Model 500A may be employed as a tachometer by connecting a suitable phototube to the instrument. A source of light to be reflected into the phototube, by a target painted on the rotating machinery being measured, must also be provided.

The above mentioned phototube and light source have been combined into one assembly and may be purchased from the Hewlett-Packard Co. This accessory is called a Model 506A Tachometer Head Assembly.

Zero Meter Indication - The meter pointer may not coincide with the zero scale mark when the instrument is not operating. The meter pointer is correctly adjusted and the adjustment screw sealed at the factory.

## Circuit Description

The Model 500A Electronic Frequency Meter consists of a limiting amplifier, an electronic switching circuit, a pulse counter circuit, a constant current regulator and a power supply.

A voltage of unknown frequency is applied to the limiting amplifier, tubes V1, V2, V3. Tubes V1 and V2 amplify and flatten the peaks of the incoming voltage. Tube V3 is a phase inverter.

The square wave obtained from the plate circuits of tubes V2 and V3 is applied to the switching circuit which is composed of tubes V4 and V5.

The space current for the two switching tubes is obtained from the constant current regulator. Alternate half cycles of the square wave causes all of the constant current to flow through tube V4 and charge one of the capacitors C9-C18. During the intervening half cycles the constant current flows through V5 and causes one of the capacitors C19-C28 to be charged. The time constants of the two RC combinations R33, C9-C18 and R32, C19-C28 are equal. The resistor and capacitor values are such that, at the highest frequency to be counted, the capacitors will be fully charged before the end of the half cycle. The accurately controlled pulses from the capacitors C9-C18 and C19-C28 are converted to unidirectional pulses by the crystal rectifiers CR1-CR4 and the resultant current is indicated by meter M1. The meter indication is proportional to the number of pulses per unit of time and therefore to the frequency of the voltage applied to the input of the instrument. The resistors R34 to R43 are shunts across the meter to adjust the current through the meter to the correct value for each frequency range.

Resistors R55 and R56 are adjusted to match the resistance of the recorder. They are automatically connected in series with the meter to compensate for the resistance of the recorder when the recorder is not connected to the instrument.

The constant current regulator consists of tubes V7, V8. Tube V8 is a voltage regulator tube which maintains a constant voltage on the screen grid of tube V7. A voltage divider R48, R49, R50 is connected between the screen grid and ground. The variable resistor (R49) in this divider is provided so that the voltage applied to the grid of V7 may be adjusted to produce the desired constant current for the switching tubes. This current is measured by switching the meter (M1) across the shunt resistor R27. This resistor is inserted in the plate circuit of tube V7.



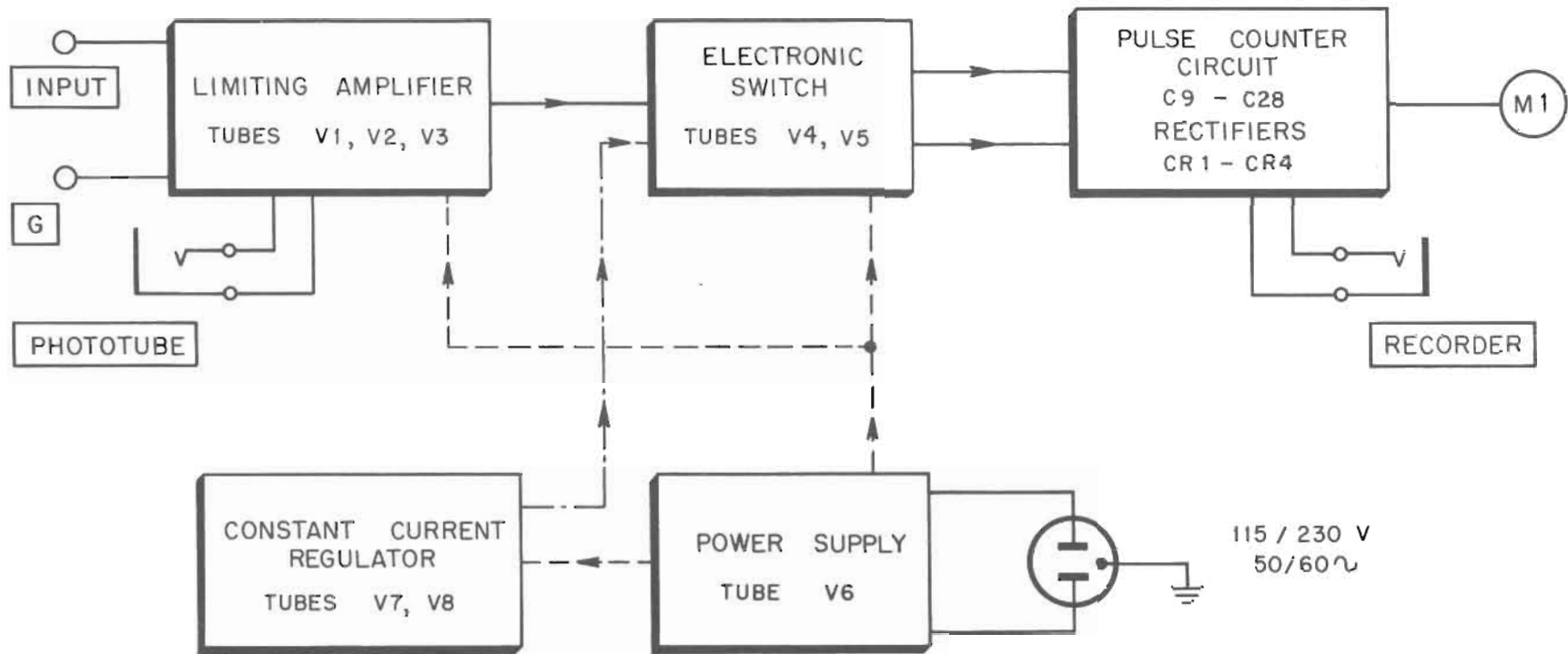

Fig. 1. Model 500A Block Diagram

## Maintenance

### Cover and Bottom Plate Removal --

The bottom plate is removed by unscrewing the four screws, one in each corner of the bottom plate, which fasten the plate to the chassis.

The cover is removed by unscrewing the eight screws which fasten the cover to the back and top of the instrument.

### Tube Replacement --

Any tube having RTMA standard characteristics may be used for replacement purposes in this instrument.

### Hum Balance Adjustment (R55) --

The adjustment of the variable resistor for balancing out the unwanted 60 $\lambda$  current is as follows:

1. Measure and note the power line frequency. Shield the INPUT terminals of the instrument. A shielded double banana plug is satisfactory.
2. Set the USE-LINE FREQ. -CALIBRATE switch to USE and the RANGE switch to the 50 $\lambda$  position.
3. Adjust R55, located underneath the chassis and reached by removing the bottom plate (See Fig. 4), for minimum meter (M1) indication.
4. Measure the line frequency and compare with previous line frequency measurement. If they are not the same, re-adjust R55 slightly to one side so that the line frequency is correct.

### Frequency Calibration Adjustment --

The only calibration adjustment that should be performed in the field is the adjustment of the meter shunt resistors R34 to R43. If any of the coupling capacitors C9 to C28 are affecting the calibration, the instrument should be returned to the factory for adjustment.

The procedure for adjusting the shunt resistors is as follows:

1. Warm up the instrument and set the controls for frequency measurement.
2. Starting with the RANGE switch at the 50 $\lambda$  position, apply a 50 $\lambda$  voltage to the INPUT terminals of the instrument. This voltage should be obtained from a secondary frequency standard or some other source of accurate frequencies. If the meter does not indicate exactly full scale, then adjust the value of the shunt resistor R34 by substituting another resistor or by connecting a high resistance in parallel with R34.

500A 4/24/53 Serial 1765 to

3. Repeat step 2 for 100 $\mu$ , 200 $\mu$  and etc. using a calibration voltage whose frequency is equal to the full scale frequency of each range. Adjust the shunt resistor which corresponds to the range being calibrated.

#### Adjustment of Current Regulator --

The procedure for adjusting the constant current regulator circuit is as follows:

1. Warm up the instrument using 115V line voltage. Set the USE-LINE FREQ. -CALIBRATE switch to CALIBRATE. Adjust the CALIBRATE control so that the meter indicates exactly 80 on the 0 to 100 scale.

2. Change the line voltage to 105 volts and note the meter indication. Repeat at 125 volts line voltage. If the meter indication does not change more than  $\pm 1\%$  of full scale (80.5 to 79.5), then the regulator circuit is functioning satisfactorily.

3. If the meter indication is not within the specified limits, then a new OD3 tube (V8) and/or a new 6L6 tube (V7) should be tried. The OD3 tube should be aged by operating it for eight hours with 150 volts applied across its terminals. The easiest way to age the tube is to put it in its socket in the instrument and let the instrument operate for eight hours.

If changing tubes does not restore the regulator circuit to normal, then additional adjustments will be necessary.

4. With the line voltage at 115 volts, set the USE-LINE FREQ. -CALIBRATE switch at CALIBRATE. Set the CALIBRATE control to produce a meter indication of 80, then change the USE---CALIBRATE switch to USE and apply a 50,000 cycles/sec. voltage to the INPUT terminals. Note the meter indication.

5. Adjust R61, (See Resistor Board Detail RB1, Fig. 5) by connecting a resistor in parallel with R61 or by substituting a new resistor of higher value, so that the meter does not vary more than  $\pm 1\%$  of full scale when the power line voltage is varied from 105 to 125 volts.

6. Without changing the CALIBRATE control, change the RANGE switch and input frequency to 1000 cycles/sec. Note the meter indication with 115 volts power line voltage. Change power line voltage to 105 and 125 volts and note any variations from the indication obtained at 115 volts. If the variation is  $\pm 1\%$  or less, the circuit is correctly adjusted.

However, if the variation is more than  $\pm 1\%$  then the value of R61 should be changed so as to obtain the best compromise between the 1000 and 50,000 cycles/sec. adjustments.

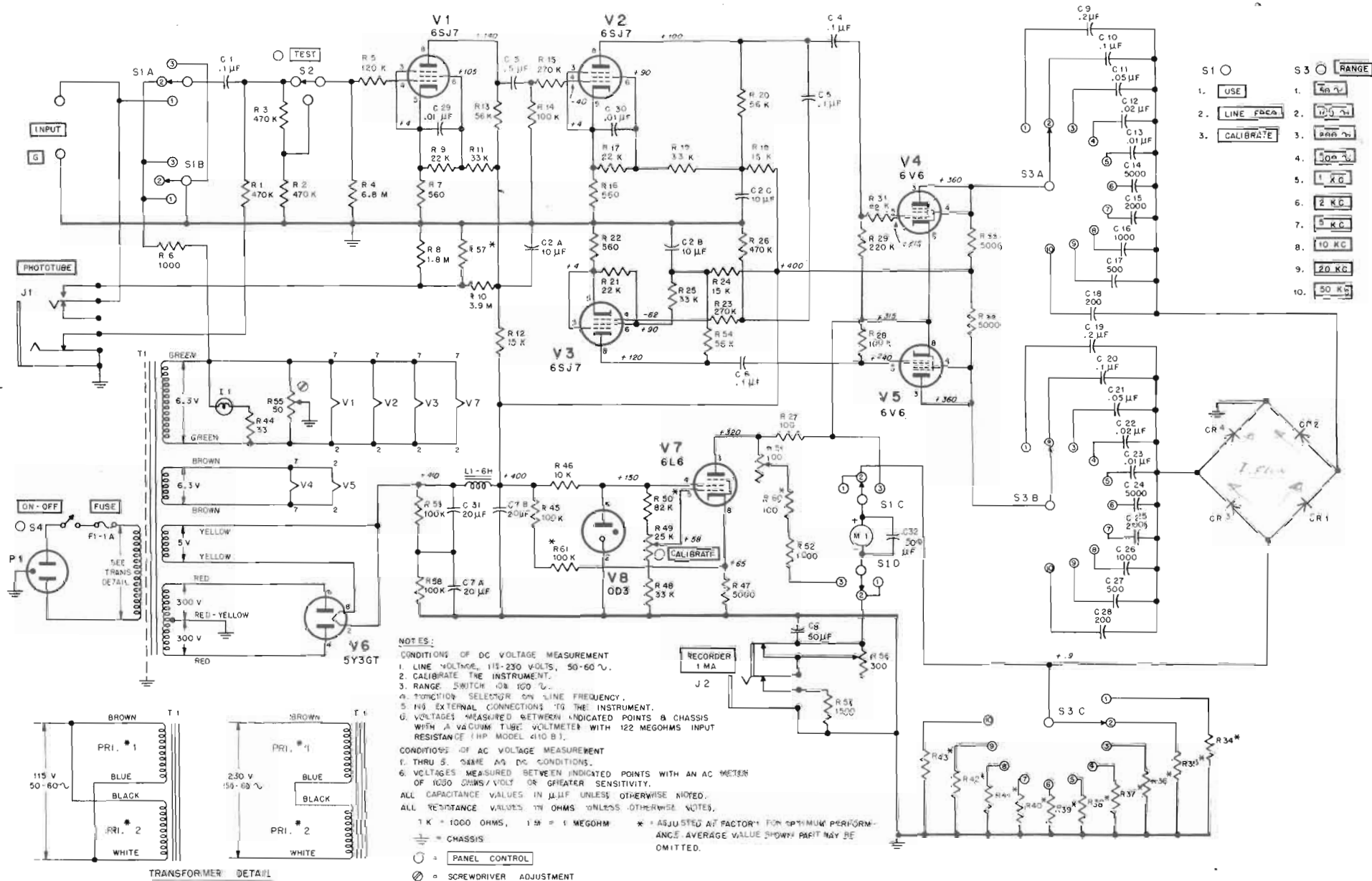

**SCHEMATIC DIAGRAM OF MODEL 500A  
 SERIAL 2315 & ABOVE.**



Fig. 2. Model 500A Electronic Frequency Meter

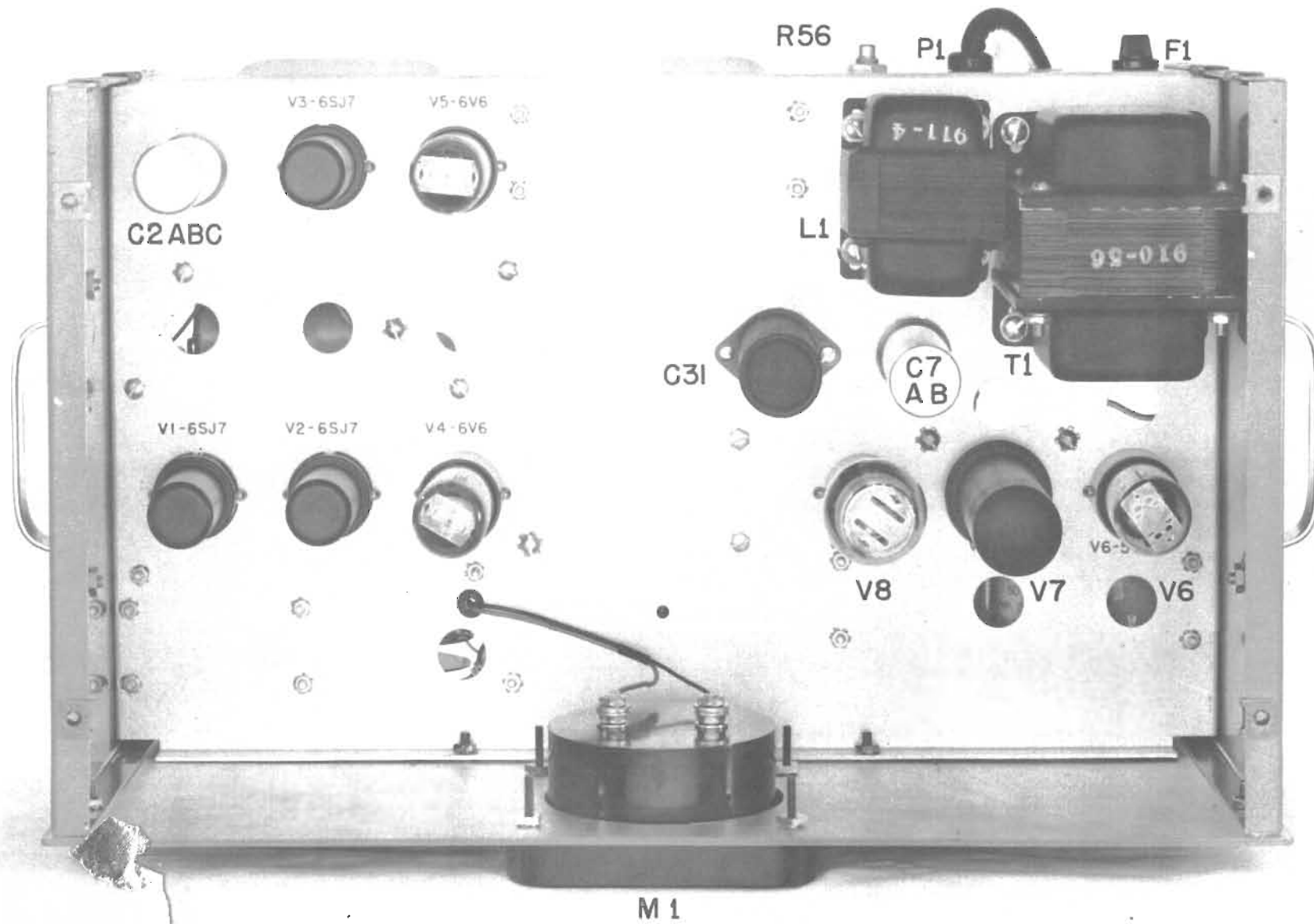

Fig. 3. Model 500A Top View Cover Removed

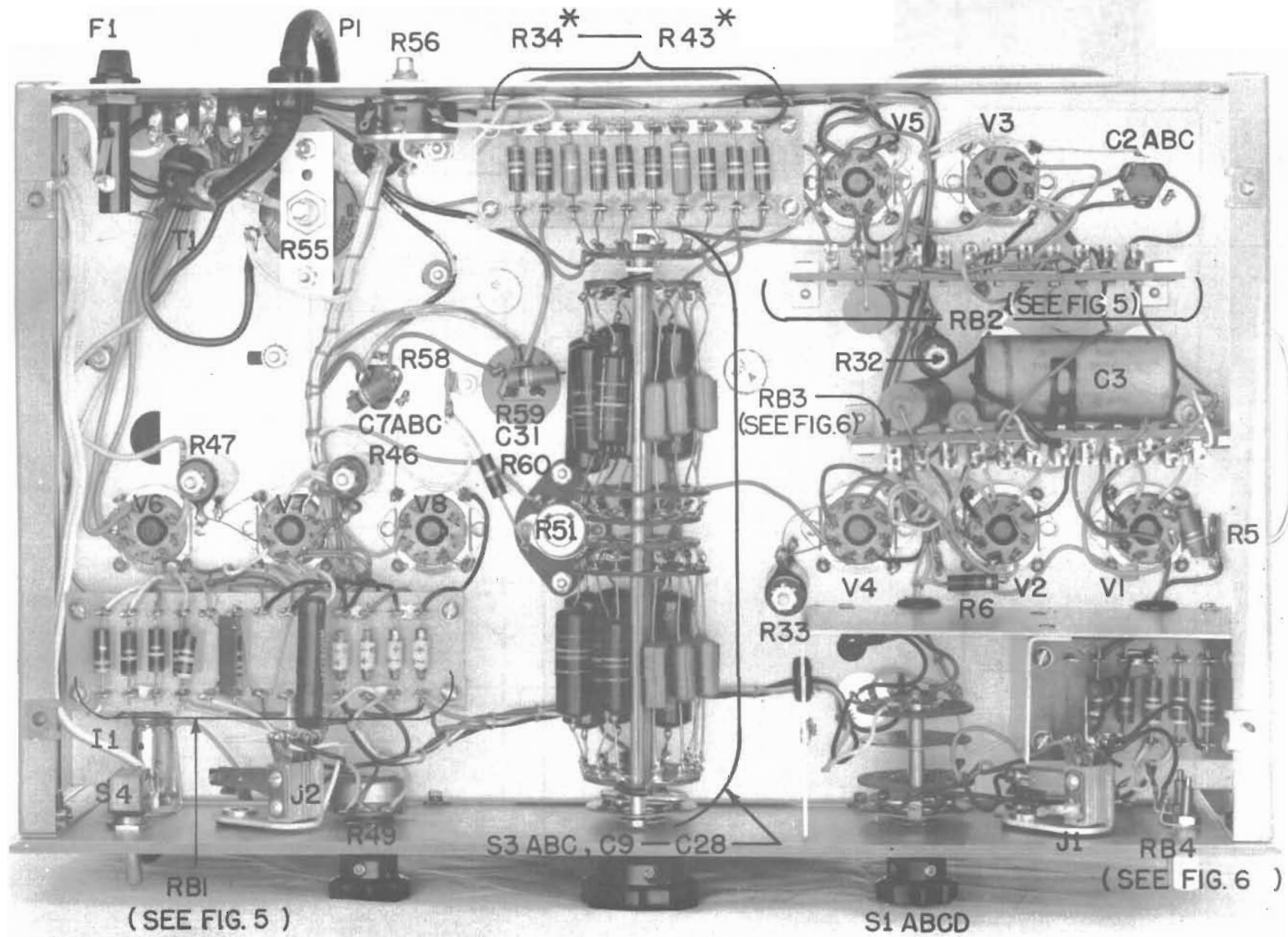
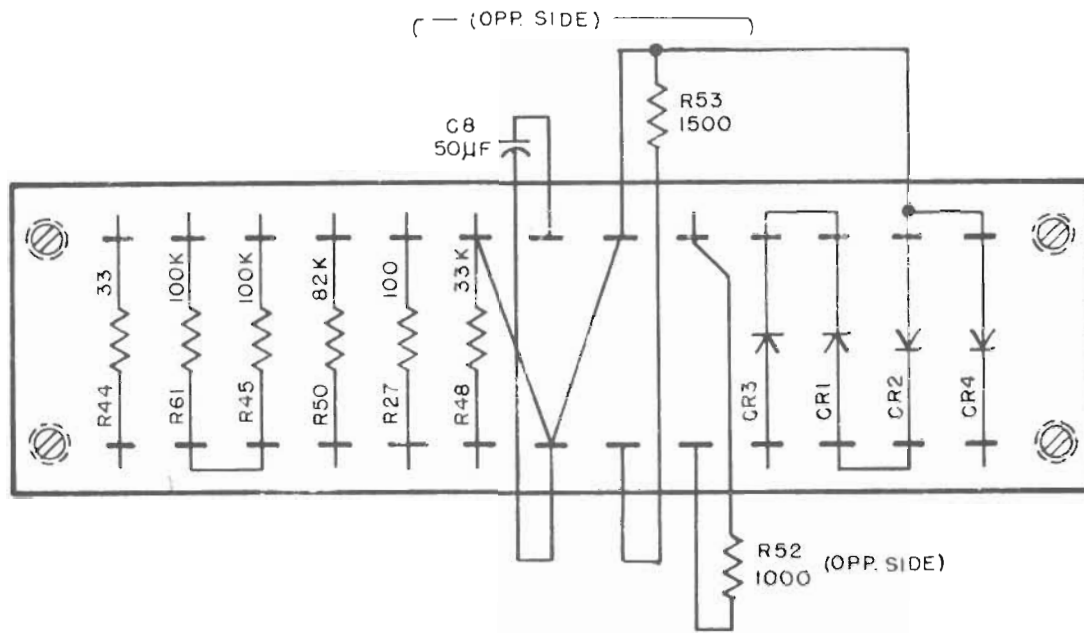
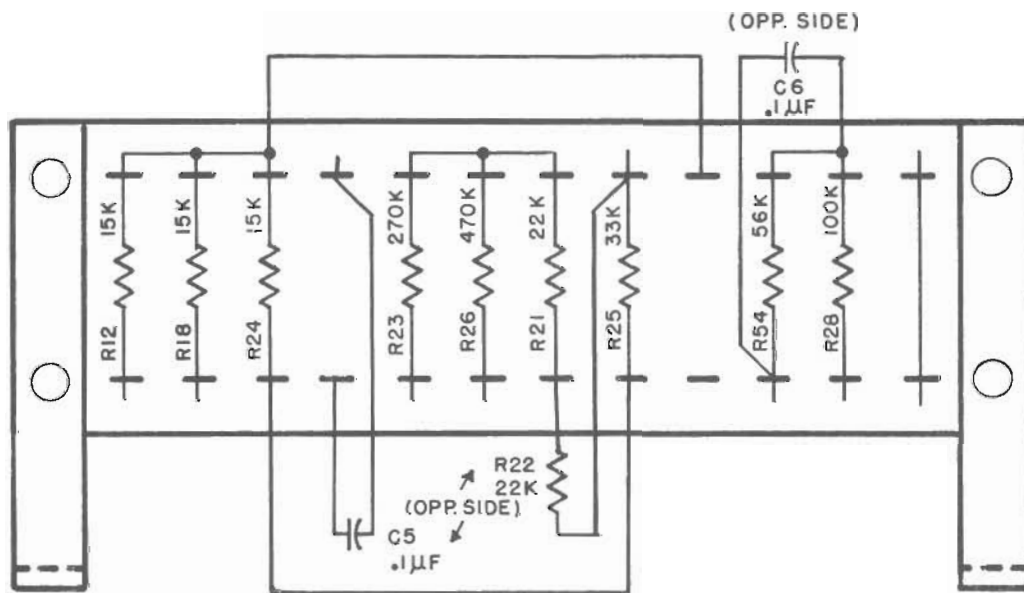

Fig. 4. Model 500A Bottom View Bottom Plate Removed



RB1



RB2

Fig. 5. Model 500A Resistor Board Detail



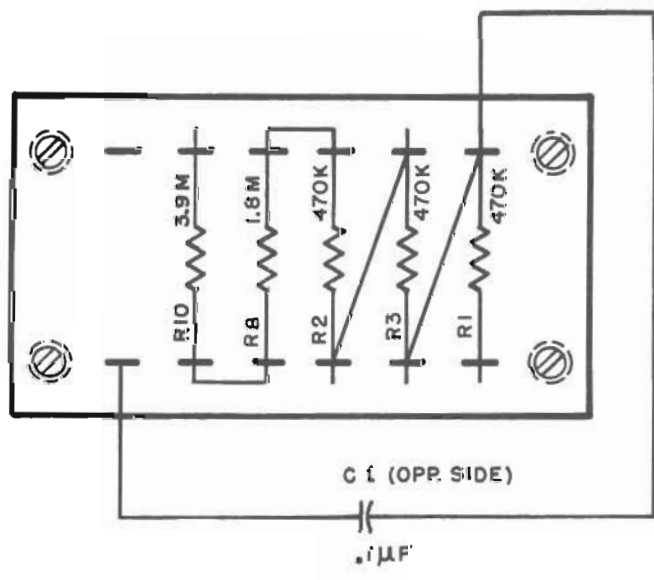
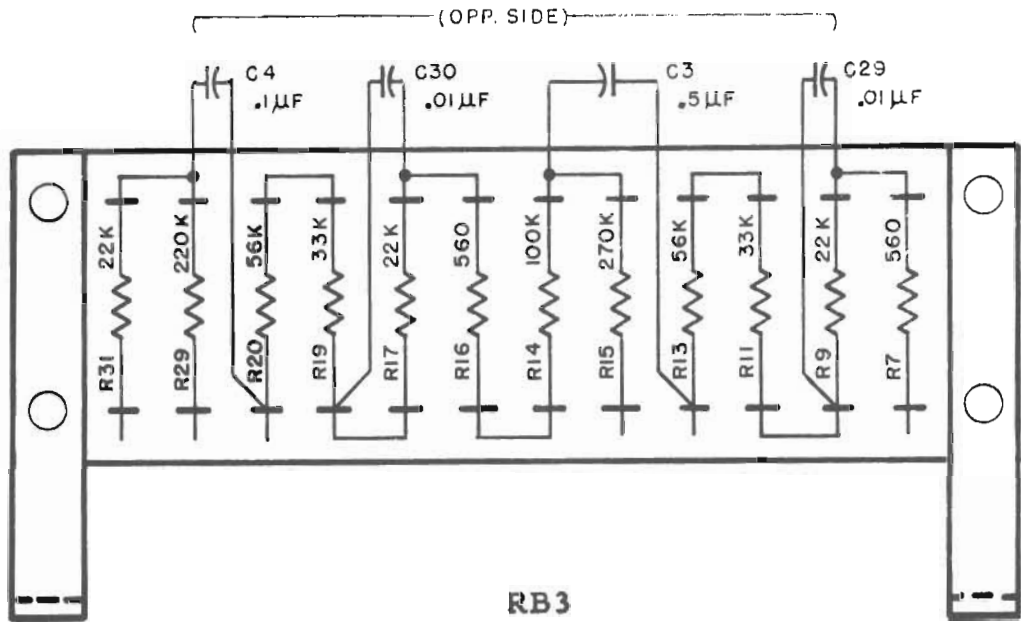

Fig. 6. Model 500A Resistor Board Detail

TABLE OF REPLACEABLE PARTS

Circuit Ref.	Description	-hp- Stock No.	Mfr. * & Mfrs. Designation
C1	Capacitor: fixed, paper, .1 $\mu$ f, $\pm 10\%$ , 600 vdcw	16-1	CC #73P10496
C2	Capacitor: fixed, electrolytic, 10, 10, 10 $\mu$ f, 450 vdcw	18-31	X FPT-389
C3	Capacitor: fixed, paper, .5 $\mu$ f, $\pm 10\%$ , 400 vdcw	16-58	CC #4TM-P5
C4, C5, C6	Capacitor: fixed, paper, .1 $\mu$ f, $\pm 10\%$ , 600 vdcw	16-1	CC #73P10496
C7 AB	Capacitor: fixed, electrolytic, 20, 20 $\mu$ f, 450 vdcw	18-22	A AEF-"1X3"
C8	Capacitor: fixed, electrolytic, 50 $\mu$ f, +200%, -10%, 50 vdcw	18-50	X TC-39
C9 - C28	Part of Range Switch Assembly		
C29, C30	Capacitor: fixed, paper, .01 $\mu$ f, $\pm 10\%$ , 600 vdcw	16-11	A Type F688
C31	Capacitor: fixed, electrolytic, 20 $\mu$ f, 450 vdcw	18-20	X FPS-144
R1, R2, R3	Resistor: fixed, composition, 470,000 ohms, $\pm 10\%$ , 1 W	24-470K	B GB 4741
R4	Resistor: fixed, composition, 6.8 megohms, $\pm 10\%$ , 1 W	24-6.8M	B GB 6851
R5	Resistor: fixed, composition, 120,000 ohms, $\pm 10\%$ , 1 W	24-120K	B GB 1241
R6	Resistor: fixed, composition, 1000 ohms, $\pm 10\%$ , 1 W	24-1000	B GB 1021
R7	Resistor: fixed, composition, 560 ohms, $\pm 10\%$ , 1 W	24-560	B GB 5611
R8	Resistor: fixed, composition, 1.8 megohms, $\pm 10\%$ , 1 W	24-1.8M	B GB 1.851
R9	Resistor: fixed, composition, 22,000 ohms, $\pm 10\%$ , 1 W	24-22K	B GB 2231
R10	Resistor: fixed, composition, 3.9 megohms, $\pm 10\%$ , 1 W	24-3.9M	B GB 3.951
R11	Resistor: fixed, composition, 33,000 ohms, $\pm 10\%$ , 1 W	24-33K	B GB 3331

\*See "List of Manufacturers Code Letters For Replaceable Parts Table."

500A 4/24/53 Serial 1765 to

TABLE OF REPLACEABLE PARTS

Circuit Ref.	Description	-hp- Stock No.	Mfr. * & Mfrs. Designation
R12	Resistor: fixed, composition, 15,000 ohms, $\pm 10\%$ , 1 W	24-15K	B GB 1531
R13	Resistor: fixed, composition, 56,000 ohms, $\pm 10\%$ , 1 W	24-56K	B GB 5631
R14	Resistor: fixed, composition, 100,000 ohms, $\pm 10\%$ , 1 W	24-100K	B GB 1041
R15	Resistor: fixed, composition, 270,000 ohms, $\pm 10\%$ , 1 W	24-270K	B GB 2741
R16	Resistor: fixed, composition, 560 ohms, $\pm 10\%$ , 1 W	24-560	B GB 5611
R17	Resistor: fixed, composition, 22,000 ohms, $\pm 10\%$ , 1 W	24-22K	B GB 2231
R18	Resistor: fixed, composition, 15,000 ohms, $\pm 10\%$ , 1 W	24-15K	B GB 1531
R19	Resistor: fixed, composition, 33,000 ohms, $\pm 10\%$ , 1 W	24-33K	B GB 3331
R20	Resistor: fixed, composition, 56,000 ohms, $\pm 10\%$ , 1 W	24-56K	B GB 5631
R21	Resistor: fixed, composition, 22,000 ohms, $\pm 10\%$ , 1 W	24-22K	B GB 2231
R22	Resistor: fixed, composition, 560 ohms, $\pm 10\%$ , 1 W	24-560	B GB 5611
R23	Resistor: fixed, composition, 270,000 ohms, $\pm 10\%$ , 1 W	24-270K	B GB 2741
R24	Resistor: fixed, composition, 15,000 ohms, $\pm 10\%$ , 1 W	24-15K	B GB 1531
R25	Resistor: fixed, composition, 33,000 ohms, $\pm 10\%$ , 1 W	24-33K	B GB 3331
R26	Resistor: fixed, composition, 470,000 ohms, $\pm 10\%$ , 1 W	24-470K	B GB 4741
R27	Resistor: fixed, wirewound, 100 ohms	5A-26	HP
R28	Resistor: fixed, composition, 100,000 ohms, $\pm 10\%$ , 1 W	24-100K	B GB 1041

\*See "List of Manufacturers Code Letters For Replaceable Parts Table."

TABLE OF REPLACEABLE PARTS

Circuit Ref.	Description	-hp- Stock No.	Mfr. * & Mfrs. Designation
R29	Resistor: fixed, composition, 220,000 ohms, $\pm 10\%$ , 1 W	24-220K	B GB 2241
R30	Resistor: fixed, composition, 270,000 ohms, $\pm 10\%$ , 1 W	24-270K	B GB 2741
R31	Resistor: fixed, composition, 22,000 ohms, $\pm 10\%$ , 1 W	24-22K	B GB 2231
R32, R33	Resistor: fixed, wirewound, 5000 ohms, $\pm 10\%$ , 20 W	27-3	S Type 2R
R34-R43	Electrical value adjusted at factory		
R44	Resistor: fixed, composition, 33 ohms, $\pm 10\%$ , 1 W	24-33	B GB 3301
R45	Resistor: fixed, composition, 100,000 ohms, $\pm 10\%$ , 1 W	24-100K	B GB 1041
R46	Resistor: fixed, wirewound, 10,000 ohms, $\pm 10\%$ , 27 W	27-4	S Type 2R
R47	Resistor: fixed, wirewound, 5000 ohms, $\pm 10\%$ , 20 W	27-3	S Type 2R
R48	Resistor: fixed, composition, 33,000 ohms, $\pm 10\%$ , 1 W	24-33K	B GB 3331
R49	Resistor: variable, composition, 25,000 ohms, linear taper	210-54	B
R50	Resistor: fixed, composition, 82,000 ohms, $\pm 10\%$ , 1 W Electrical value adjusted at factory	24-82K	B
R51	Resistor: variable, wirewound, 100 ohms, linear taper	M-80	HP
R52	Resistor: fixed, wirewound, 1000 ohms, $\pm 10\%$ , 1 W	26-15	R Type BW-1
R53	Resistor: fixed, composition, 1500 ohms, $\pm 1\%$ , 1 W	31-1500	GG Type CP-1
R54	Resistor: fixed, composition, 56,000 ohms, $\pm 10\%$ , 1 W	24-56K	B GB 5631
R55	Resistor: variable, wirewound, 50 ohms, $\pm 10\%$ , 3 W	210-2	G #21-010-067

\*See "List of Manufacturers Code Letters For Replaceable Parts Table."

500A. 4/24/53 Serial 1765 to

TABLE OF REPLACEABLE PARTS

Circuit Ref.	Description	-hp- Stock No.	Mfr. * & Mfrs. Designation
R56	Resistor: variable, wirewound, 300 ohms, linear taper	210-53	G #21-010-358
R57	Electrical value adjusted at factory		
R58, R59	Resistor: fixed, composition, 100,000 ohms, ±10%, 1 W	24-100K	B GB 1041
R60, R61	Resistor: fixed, composition, 100,000 ohms, ±10%, 1 W Electrical value adjusted at factory	24-100K	B GB 1041
	Binding Post:	312-3	HP
CR1-CR4	Crystal Rectifier:	212-G11B	HP (IN 34)
F1	Fuse: 1 A Fuseholder:	211-18 312-8	T, #1040 T, #342001
	Indicator Lamp Assembly:	312-10	BB, #807BS
	Knob: 1-1/2" diam.	37-11	HP
	Knob: 2" diam.	37-13	HP
II	Lamp:	211-47	O, Mazda #47
J1	Telephone Jack:	38-25	X, #706
J2	Telephone Jack:	38-194	Switchcraft, Inc.
M1	Meter:	112-17	HP
P1	Power Cable:	812-56	HP
L1	Reactor: 6 H @ 125 MA, 240 ohms	911-4	HP
S1 AB	Rotary Switch:	310-69	HP
S2	Push Button Switch:	310-53	Switchcraft #1003
S3 ABC	Range Switch Assembly	5A-19W	HP
S4	Toggle Switch:	310-11	D, 20994NV
T1	Power Transformer:	910-56	HP
V1, V2, V3	Tube: 6SJ7	212-6SJ7	ZZ
V4, V5	Tube: 6V6	212-6V6	ZZ
V6	Tube: 5Y3GT	212-5Y3GT	ZZ
V7	Tube: 6L6	212-6L6	ZZ
V8	Tube: OD3	212-OD3	ZZ

\*See "List of Manufacturers Code Letters For Replaceable Parts Table."

LIST OF MANUFACTURERS CODE LETTERS  
FOR REPLACEABLE PARTS TABLE

<u>Code Letter</u>	<u>Manufacturer</u>
A	Aerovox Corp.
B	Allen-Bradley Co.
C	Amperite Co.
D	Arrow, Hart and Hegeman
E	Bussman Manufacturing Co.
F	Carborundum Co.
G	Centralab
H	Cinch Manufacturing Co.
HP	Hewlett-Packard
I	Clarostat Manufacturing Co.
J	Cornell Dubilier Electric Co.
K	Hi-Q Division of Aerovox Corp.
L	Erie Resistor Corp.
M	Federal Telephone and Radio Corp.
N	General Electric Co.
O	General Electric Supply Corp.
P	Girard-Hopkins
R	International Resistance Co.
S	Lectrohm, Inc.
T	Littelfuse, Inc.
V	Micamold Radio Corp.
X	P. R. Mallory Co., Inc.
Z	Sangamo Electric Co.
AA	Sarkes Tarzian
CC	Sprague Electric Co.
DD	Stackpole Carbon Co.
EE	Sylvania Electric Products, Inc.
FF	Western Electric Co.
HH	Amphenol
II	Dial Light Co. of America
KK	Switchcraft, Inc.
LL	Gremer Mfg. Co.
MM	Carad Corp.
ZZ	Any tube having RETMA standard characteristics

## CLAIM FOR DAMAGE IN SHIPMENT

The instrument should be tested as soon as it is received. If it fails to operate properly, or is damaged in any way, a claim should be filed with the carrier. A full report of the damage should be obtained by the claim agent, and this report should be forwarded to us. We will then advise you of the disposition to be made of the equipment and arrange for repair or replacement. Include model number, type number and serial number when referring to this instrument for any reason.

## WARRANTY

Hewlett-Packard Company warrants each instrument manufactured by them to be free from defects in material and workmanship. Our liability under this warranty is limited to servicing or adjusting any instrument returned to the factory for that purpose and to replace any defective parts thereof (except tubes, fuses and batteries). This warranty is effective for one year after delivery to the original purchaser when the instrument is returned, transportation charges prepaid by the original purchaser, and which upon our examination is disclosed to our satisfaction to be defective. If the fault has been caused by misuse or abnormal conditions of operation, repairs will be billed at cost. In this case, an estimate will be submitted before the work is started.

If any fault develops, the following steps should be taken:

1. Notify us, giving full details of the difficulty, and include the model number, type number and serial number. On receipt of this information, we will give you service instruction or shipping data.
2. On receipt of shipping instruction, forward the instrument prepaid, and repairs will be made at the factory. If requested, an estimate of the charges will be made before the work begins provided the instrument is not covered by the warranty.

## SHIPPING

All shipments of Hewlett-Packard instruments should be made via Railway Express. The instruments should be packed in a wooden box and surrounded by two to three inches of excelsior or similar shock-absorbing material.

DO NOT HESITATE TO CALL ON US

HEWLETT-PACKARD COMPANY

*Laboratory Instruments* for Speed and Accuracy

395 PAGE MILL ROAD  PALO ALTO, CALIFORNIA